

HF68 Series Flow Switch



Application:

This switch is a single pole double throw (SPDT) flow switch, used to detect and observe the liquid flow rate relay, normally for air adjustment and applications in the field of water supply equipment. It is used to sense the change of the flow rate of the liquid, such as water, ethylene, glycol or other non-hazardous liquid passing through the pipeline, with the typical application as locations where the interlocking effect or "flow breaking" protection is necessary.

Size and specification:

- Case 64×64×48mm (Type:HF68S Stainless Steel)
- Case 64×64×48mm (Type:HF68A Brass Type)
- Case 52×52×48mm (Type:HF68B Brass Type)
- Case 64×64×48mm (Type:HF68P with a nylon connector)

Electric parameters:

Rated value of the switch connector:
 5A, 1/4HP, 125VAC~250VAC
 10A, 1/4HP, 125VAC~250VAC
 15A, 1/2HP, 125VAC~250VAC
 Micro switch has follow certification standards:



Wiring:

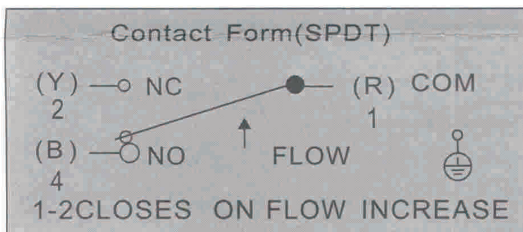

Connector "1"-red line
 Connector "2"-yellow line
 Connector "4"-blue line

Parameter:

Max. working pressure:
 1.6Mpa (Type: HF68A, HF68B)
 (3.0Mpa HF68A special)
 1.1Mpa (Type: HF68P)
 3.0Mpa (Type: HF68S)
 (4.0Mpa HF68S special)
Connector: 1'NPT, 3/4'NPT, 1/2'NPT,
 1-1/4NPT

Range of flow:

- 18L/M~2000L/M (standard)
- 5L/M~3000L/M (nonstandard)

Liquid temperature:

- -20°C~120°C (Type: HF68A, HF68B)
- -45°C~260°C (Type: HF68S stainless steel)
- -25°C~100°C (Type: HF68P nylon connector)

Typical Flow Rates

Table 1

		Required to Actuate Switch (m ³ /hr)								
Pipe Size (in.)		1	1/4	1/2	2	2 1/2	3	4	5	6
Minimum Adjustment	Flow Increase 1-2 (C-A) close	0.88	1.4	1.8	2.6	3.3	4.1	5.4	8.0	10.8
	Flow Decrease 1-4 (C-B) close	0.71	1.1	1.47	1.9	2.3	2.4	3.9	5.8	7.9
Maximum Adjustment	Flow Increase 1-2 (C-A) close	7.32	12.1	16.6	23.7	25	31	43.9	68.7	99
	Flow Decrease 1-4 (C-B) close	5.10	8.3	10.7	13	20	24	33	47	63

Supply 8-inch flow paddle for special requirement

PRESSURE DROP CHARACTERISTICS

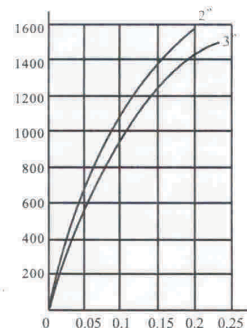
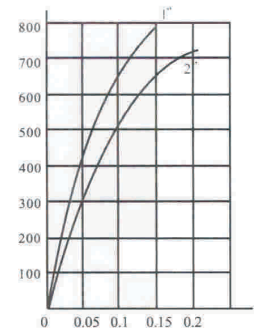
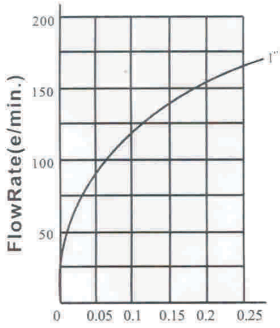

1" Paddle
2" Paddle
3" Paddle

Pressure Drop(kgf/cm²)

Right installation and adjustment:

NOTE: In order to sense the change of flow, the flow paddle can't touch the pipe or any throttling devices in pipe.

NOTE: Wrong operation will cause danger!
The factory setting is at the minimum flow rate (see Table 1).
Don't adjust the flow rate lower than the factory setting as this may result in the switch failing to return to a "no flow" position.
In order to work in the cold medium (below 0°C), the device must be kept warm (above 0°C) to prevent from wrong action.

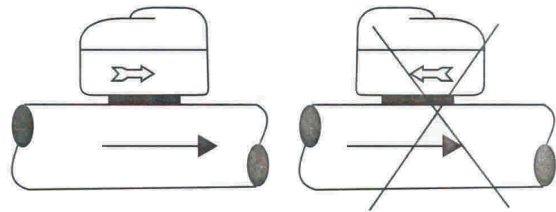

HF68 flow switch must be installed in the beeline pipe, which have at least 5 times pipe larger on both of the side (See Fig.2).

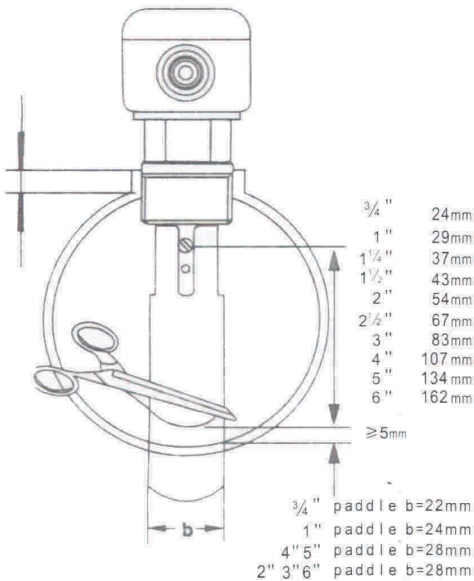
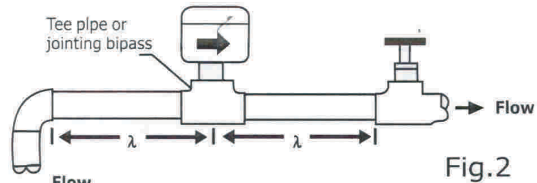

Fig.1 Adjust Flow Paddle



Size "λ" must be at least 5 times pipe from the nearest bend, valve or other throttling devices in pipe.

How to adjust :

- 1、 Take off the cover.
- 2、 For higher flow rates, turn the adjusting screw clockwise. When the flow value has been adjusted higher than the factory setting and then you want to adjust it lower, turn the adjusting screw counter-clockwise. (See Fig.3)
- 3、 Don't adjust the flow rate lower than the factory setting

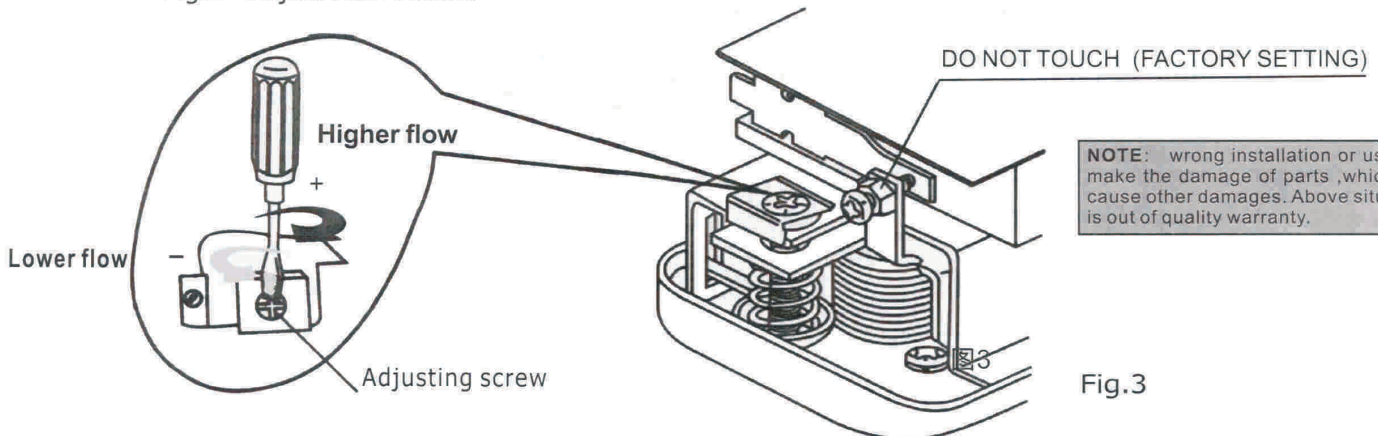

Fig.3